

# R5 RA 0400-0630 C

Oil-lubricated rotary vane vacuum pumps



VACUUM SOLUTIONS



## Reliable

Robust construction, highly resilient carbon fiber vanes, proven rotary vane technology, long service life

## High performance

High pumping speed at low pressures, designed for continuous operation

## Flexible

Various design options available, easy adaption to individual customer requirements and processes, variable speed drive available

### Accessories

- IEC (IE3) and NEMA motors
- Multi-voltage, multi-frequency motors (IE3) for variable speed drive
- Single or double gas-ballast valve, manual or solenoid operation
- Various inlet filters
- Various temperature and pressure gauges
- Starter units
- Oil mist separator
- Energy recuperation kit with heat exchanger
- Vacuum pump oils for all applications

# R5 RA 0400-0630 C

Oil-lubricated rotary vane vacuum pumps



VACUUM SOLUTIONS

Dimensional drawing

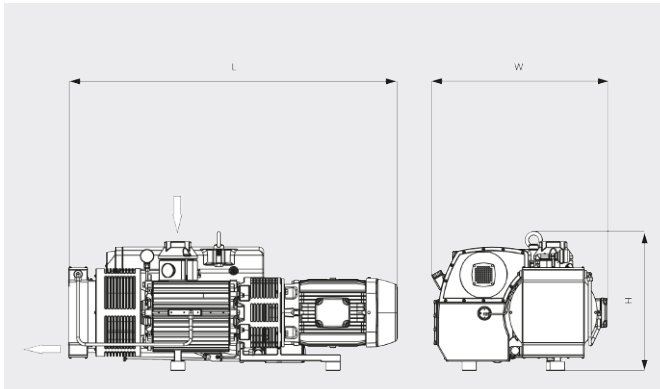

Pumping speed

Air at 20°C. Tolerance: ± 10%

— 50 Hz ..... 60 Hz

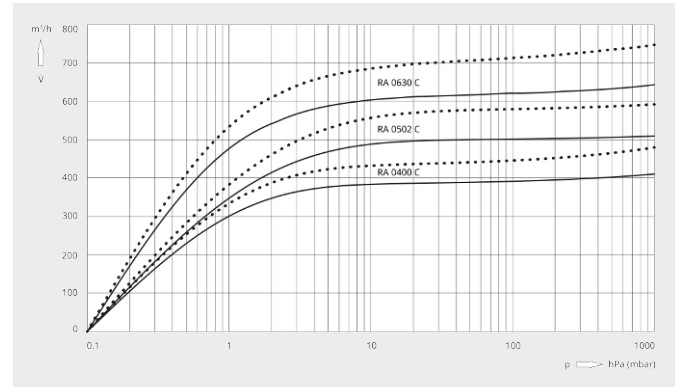

|  | R5 RA 0400 C                               | R5 RA 0502 C                               | R5 RA 0630 C                               |
|--|--|--|--|
| Nominal pumping speed                  | 410 / 480 m³/h (50 / 60 Hz)                | 510 / 590 m³/h (50 / 60 Hz)                | 630 / 760 m³/h (50 / 60 Hz)                |
| Ultimate pressure                      | 0.1 hPa (mbar) (50 / 60 Hz)                | 0.1 hPa (mbar) (50 / 60 Hz)                | 0.1 hPa (mbar) (50 / 60 Hz)                |
| Nominal motor rating                   | 11 / 15 kW (50 / 60 Hz)                    | 11 / 15 kW (50 / 60 Hz)                    | 15 / 18.5 kW (50 / 60 Hz)                  |
| Nominal motor speed                    | 1000 / 1200 min <sup>-1</sup> (50 / 60 Hz) | 1000 / 1200 min <sup>-1</sup> (50 / 60 Hz) | 1000 / 1200 min <sup>-1</sup> (50 / 60 Hz) |
| Power consumption at 100 mbar          | 8.2 / 10.0 kW (50 / 60 Hz)                 | 9.9 / 12.0 kW (50 / 60 Hz)                 | 15 / 18.5 kW (50 / 60 Hz)                  |
| Power consumption at ultimate pressure | 4.7 / 5.6 kW (50 / 60 Hz)                  | 5.8 / 6.4 kW (50 / 60 Hz)                  | 6.5 / 8.0 kW (50 / 60 Hz)                  |
| Noise level (ISO 2151)                 | 77 / 79 dB(A) (50 / 60 Hz)                 | 77 / 79 dB(A) (50 / 60 Hz)                 | 77 / 79 dB(A) (50 / 60 Hz)                 |
| Oil capacity                           | 12 l                                       | 12 l                                       | 15 l                                       |
| Weight approx.                         | 435 kg                                     | 530 kg                                     | 550 kg                                     |
| Dimensions (L x W x H)                 | 1309 x 862 x 711 mm                        | 1374 x 864 x 712 mm                        | 1723 x 912 x 712 mm                        |
| Gas inlet / outlet                     | G 3" / G 3"                                | G 3" / G 3"                                | G 3" / G 3"                                |

DO YOU WANT TO KNOW MORE?

Get in touch with us directly!



CONTACT FORM